

MO-H

CHARACTERISTICS

CERTIFICATES



- Assessed for non-carbonated concrete class from C12/15 to C50/60.
- Post-installed rebar from $\varnothing 8$ to $\varnothing 25$.
- Use for high loads.
- Styrene free.
- Easy set up.
- Use for static or quasi-static loads.
- Temperature range: from -40°C to $+80^{\circ}\text{C}$ (long term maximum temperature $+50^{\circ}\text{C}$).
- Suitable for dry and wet concrete holes.
- Certificate of contact with drinking water (WRAS).
- Fire resistance certificate for studs and rebar (IBMB).
- Suitable for roof setting-up.

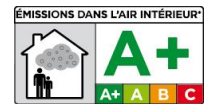

APPLICATIONS

- Overlapping joints with existing reinforcement in a building component.
- Anchoring of the reinforcement at a slab or beam support, end support/bearing of a slab designed as simply supported as well as its reinforcement for restraint forces.
- Anchoring of reinforcement of building components stressed primarily in compression.
- Anchoring of reinforcement to cover the line of acting tensile force.

BASE MATERIAL



VALID FOR



DRILL HOLE CONDITION

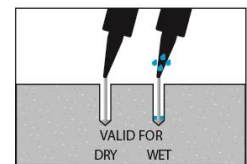

APPLICATION EXAMPLES

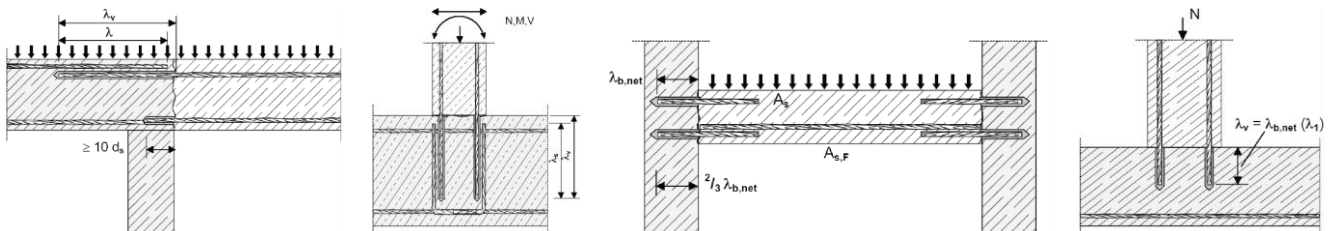

1. RANGE

ITEM	CODE	SIZE	PHOTO	COMPONENT	MATERIAL	
1	MOH300 MOH410	300 ml. 410 ml.		HYBRID RESIN STYRENE FREE	Hybrid resin styrene free Format: cartridges de 300 y 410 ml	12

2. ACCESORIES

ITEM	CODE	PHOTO	COMPONENT	MATERIAL
1	MOPISSI		APPLICATION GUNS	Gun for 300 ml standard cartridges
	MOPISTO			Gun for 410 ml coaxial cartridges
2	MORCEPKIT		CLEANING BRUSHES	3 Cleaning brushes kit of $\varnothing 14$, $\varnothing 20$ and $\varnothing 29$ mm.
3	MOBOMBA		CLEANING PUMP	Pump for cleaning dust and drill hole fragments
4	MORCANU		MIXING NOZZLE	Plastic. Helix static mixer.

3. PRODUCT SET UP

3.1. SETTING UP PROCEDURE

0. PROTECT YOURSELF

Always use and wear your personal protective equipment (PPE).

1. DRILLING THE HOLE

Check the concrete base is compact and porosity is insignificant. Suitable for wet or dry drill holes.

Cartridge installation temperature: ≥ 5 °C.

Base material installation temperature: MO-H $\geq +5$ °C.

Use drill in hammer mode.

Drill to the specified diameter and depth values.

2 - 6. BLOW AND CLEAN

Clear the drill holes completely of dust and fragments by following the procedure shown in the picture. If the drill hole is flooded, the water must be removed before mortar is injected.

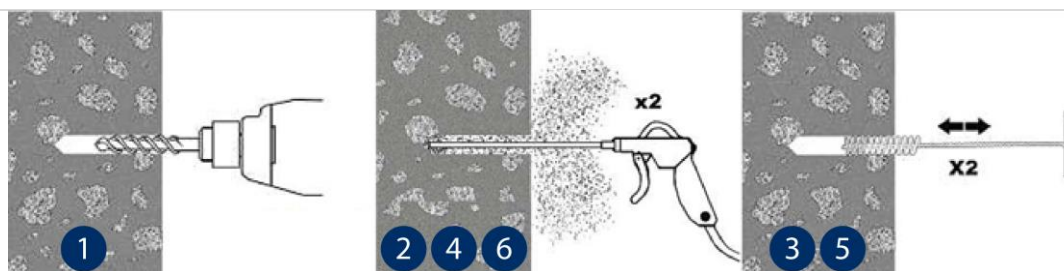

A – B* – C. OPEN CARTRIDGE

Screw the nozzle into the cartridge and place the assembly in the application gun. Squeeze on the trigger repeatedly until the mortar comes out of the nozzle in a uniform grey color. Any iridescence indicates improper mixing. Always discard the first two doses of each cartridge: these are never to be used for fixing. *For 300 ml cartridges, cut end of bag, behind seal clip.

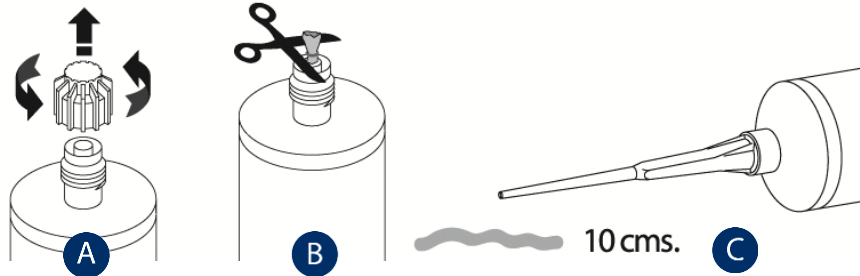

7. INJECT MORTAR

Insert the nozzle to the bottom of the drill hole and apply mortar: gradually remove the nozzle, ensuring there are no air bubbles.

Fill the hole to 1/2 and 3/4 of its depth.

In the event of not fully using the cartridge, leave nozzle attached. Only change if using again and handling time has expired, remembering to discard the first two doses of mortar.

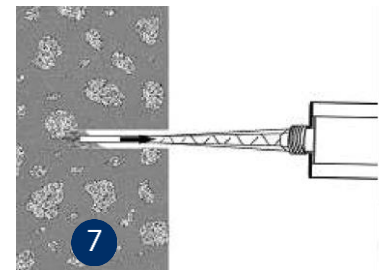

8. INSERT THE REBAR

Introduce the rebar to be installed by screwing it lightly down to the installation depth value manually; ensuring the mortar covers the rebar rivet. The introduction of the anchor must take place within the handling time. The mortar must seep from the top of the drill hole to ensure it is completely full and there are no gaps between the rebar and the drill hole.

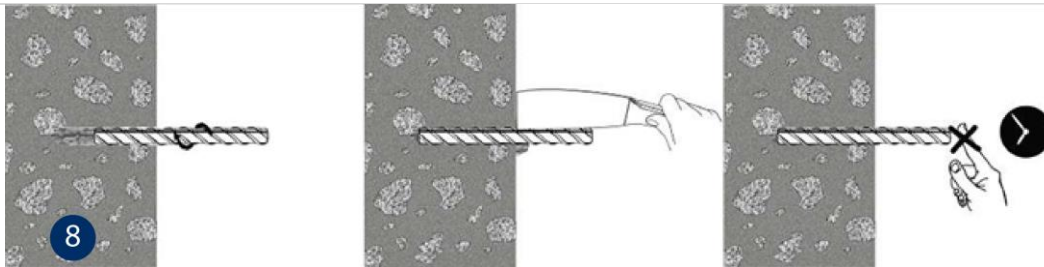

3.2 TEMPERATURE AND CURING TIME

TYPE	Base material temperature [°C]	Handling time [min]	Curing time [min]
MO-H	+5 to +10	10	145
	+10 to +15	8	85
	+15 to +20	6	75
	+20 to +25	5	50
	+25 to +30	4	40

4. STORAGE CONDITIONS

Keep the product stored in a cool, dry place, away from direct sunlight and heat sources, at an average temperature between +5 °C and +25 °C.

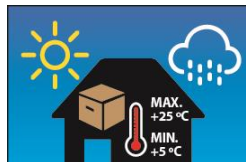

Shelf life of unopened cartridge: 18 months from the date of manufacture. The expiration date is indicated on the cartridge

The tables below are referred to EN 1992-1-1 Annex C Table C.1 and C.2N Properties of reinforcement:

5. REBAR PROPERTIES

Product form		Bars and de-coiled rods	
Class		B	C
Characteristic yield strength f_{yk} or $f_{0,2k}$ (MPa)		400 to 600	
Minimum value of $k = (f_t / f_y)k$		$\geq 1,08$	$\geq 1,15$ < 1,35
Characteristic strain at maximum force ϵ_{uk} (%)		$\geq 5,0$	$\geq 7,5$
Bendability		Bend / Rebend test	
Maximum deviation from nominal mass (individual bar) (%)	Nominal bar size (mm) ≤ 8	$\pm 6,0$	
	> 8	$\pm 4,5$	
Bond: Minimum relative rib area, $f_{R,min}$	Nominal bar size (mm) 8 to 12	0,040	
	> 12	0,056	

6. MINIMUM/MAXIMUM LENGTHS

Rebar		Minimum		Maximum
$\varnothing d_s$ [mm]	$f_{y,k}$ [N/mm ²]	Anchorage $\ell_{b,min}$ [mm]	Overlap $\ell_{0,min}$ [mm]	ℓ_{max} [mm]
8	500	114	200	40
10	500	142	200	500
12	500	171	200	600
14	500	199	210	700
16	500	227	240	800
20	500	284	300	1000
25	500	355	375	1000

7. DESIGN BOND RESISTANCE [N/mm²]

Rebar \varnothing d_s [mm]	Concrete Class								
	C12/15	C16/20	C20/25	C25/30	C30/37	C35/45	C40/50	C45/55	C50/60
8 to 16						3,4	3,7	4,0	4,3
20	1,6	2,0	2,3	2,7	3,0			3,7	
25						3,0			

8. PRECALCULATED VALUE TABLES

- Design Load Approach according to Eurocode 2 and EOTA technical report 023.
- Data information according to ETA 13/0780.
- Non-cracked concrete, dry or wet conditions
- Temperature range: -40°C to +80°C (long term maximum temperature +50°C).
- Minimum spacing conditions $\geq 5d_s$, min 50 mm:

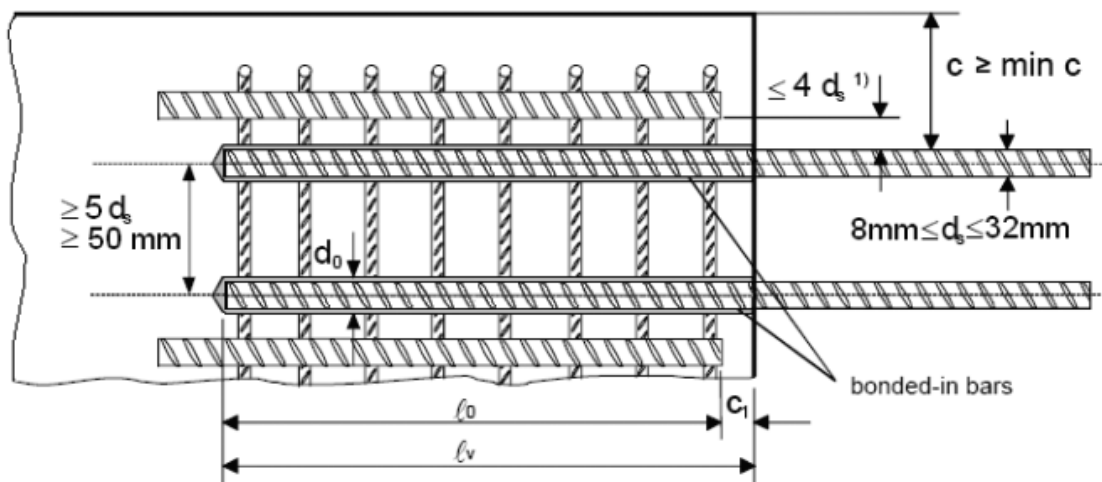

- Minimum concrete covering
 - compressed air drilling $\geq 50 + 0,06 L_b$
 - hammer drilling $\geq 30 + 0,08 L_b \geq 2\phi$
- Good bond Conditions (EU2, figure 8.2):

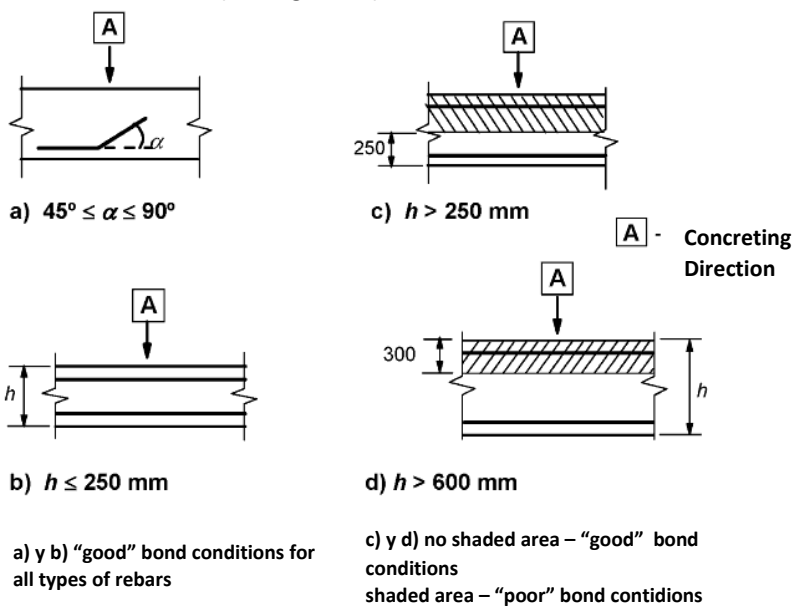

For other bond conditions, multiply resistance by 0,7.

Resistances values can be increased in the following scenarios:

- In case of transverse tension / compression pressure (α_2)
- In case of concreting cover (α_5)
- In case of overlapping (α_6)

VALUES FOR α_2 , α_5 AND α_6

INFLUENCING FACTOR	REINFORCEMENT BAR	
	IN TENSION	IN COMPRESSION
Concrete Cover	$\alpha_2 = 1 - 0,15 (c_d - \phi) / \phi$ $\geq 0,7$ $\leq 1,0$	$\alpha_2 = 1,0$
Confinement by transverse pressure	$\alpha_5 = 1 - 0,004p$ $\geq 0,7$ $\leq 1,0$	$\alpha_5 = 1$
Overlapping length	$\alpha_6 = (p_l / 25)^{0,25}$ $\geq 1,0$ $\leq 1,5$	

Where:

$c_d = \min (a/2, c_1, c)$

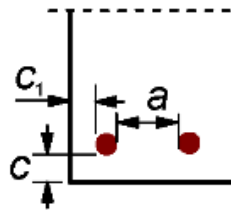

p : transverse pressure [MPa] at ultimate limit state along l_{bd}

p_1 is the percentage of reinforcement lapped within 0,65 l_0 from the centre of the lap length considered

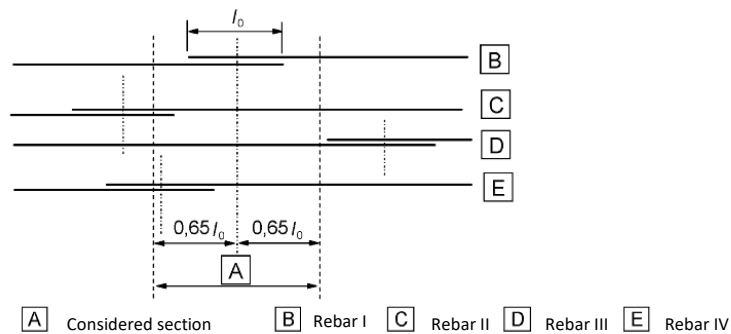

CONCRETE CLASS 20/25

Concrete compressive strength [$f_{ck,cube}$]: 25 N/mm²

Rebar ϕ	d_s	[mm]	$\phi 8$	$\phi 10$	$\phi 12$	$\phi 14$	$\phi 16$	$\phi 20$	$\phi 25$					
Rebar Size	d_s	[mm]	8	10	12	14	16	20	25					
Cross-sectional area	A_s	[mm ²]	50,3	78,5	113,1	201,1	314,2	314,2	490,9					
Steel Yield	f_{yd}	[kN]	500	500	500	500	500	500	500					
Partial safety factor	$\gamma_{M,s}$	[mm ²]	1,15	1,15	1,15	1,15	1,15	1,15	1,15					
Design steel resistance	$N_{Rd,s}$	[kN]	21,9	34,1	49,2	87,4	136,6	136,6	213,4					
Bond stress	f_{bd}	[N/mm ²]	2,30	2,30	2,30	2,30	2,30	2,30	2,30					
Drilled hole diameter	d_h	[mm]	10 ~ 12	12 ~ 14	16	18	20	25	32					
Bar spacing \geq	s	[mm]	50	50	60	80	100	100	125					
Edge distance (compressed air drilling) \geq	c	[mm]	$50 + 0,06 L_b$											
Edge distance (hammer drilling) \geq	c	[mm]	$30 + 0,08 L_b \geq 2\phi$											
Anchorage length, L_b [mm]			Design tensile pull-out bond resistance, N_{Rd} [kN]											
114	6,6	NOT ALLOWED AREA												
142	8,2								10,3					
171	9,9								12,4	14,8				
200	11,6								14,5	17,3	20,2			
210	12,1								15,2	18,2	21,2			
227	13,1								16,4	19,7	23,0	26,2		
240	13,9								17,3	20,8	24,3	27,7		
284	16,4								20,5	24,6	28,7	32,8	41,0	
300	17,3								21,7	26,0	30,3	34,7	43,4	
355	20,5								25,7	30,8	35,9	41,0	51,3	64,1
375	21,7								27,1	32,5	37,9	43,4	54,2	67,7
400	21,9								28,9	34,7	40,5	46,2	57,8	72,3
500									34,1	43,4	50,6	57,8	72,3	90,3
600			49,2	60,7	69,4	86,7	108,4							
700				66,9	80,9	101,2	126,4							
800					87,4	115,6	144,5							
900			REBAR YIELDING AREA				130,1	162,6						
1000						136,6	180,6							
Length to develop steel yield, $L_{b,rqd}$ [mm]			378	473	567	662	756	945	1.181					
Values shaded in light blue are not allowed for overlapping joints														

CONCRETE CLASS 30/37

Concrete compressive strength [$f_{ck,cube}$]: 37 N/mm²

Rebar \emptyset	d_s	[mm]	$\emptyset 8$	$\emptyset 10$	$\emptyset 12$	$\emptyset 14$	$\emptyset 16$	$\emptyset 20$	$\emptyset 25$					
Rebar Size	d_s	[mm]	8	10	12	14	16	20	25					
Cross-sectional area	A_s	[mm ²]	50,3	78,5	113,1	201,1	314,2	314,2	490,9					
Steel Yield	f_{yd}	[kN]	500	500	500	500	500	500	500					
Partial safety factor	$\gamma_{M,s}$	[mm ²]	1,15	1,15	1,15	1,15	1,15	1,15	1,15					
Design steel resistance	$N_{Rd,s}$	[kN]	21,9	34,1	49,2	87,4	136,6	136,6	213,4					
Bond stress	f_{bd}	[N/mm ²]	3,00	3,00	3,00	3,00	3,00	3,00	3,00					
Drilled hole diameter	d_h	[mm]	10 ~ 12	12 ~ 14	16	18	20	25	32					
Bar spacing \geq	s	[mm]	50	50	60	80	100	100	125					
Edge distance (compressed air drilling) \geq	c	[mm]	$50 + 0,06 L_b$											
Edge distance (hammer drilling) \geq	c	[mm]	$30 + 0,08 L_b \geq 2\phi$											
Anchorage length, L_b [mm]			Design tensile pull-out bond resistance, N_{Rd} [kN]											
114	8,6	NOT ALLOWED AREA												
142	10,7								13,4					
171	12,9								16,1	19,3				
200	15,1								18,8	22,6	26,4			
210	15,8								19,8	23,8	27,7			
27	17,1								21,4	25,7	30,0	34,2		
240	18,1								22,6	27,1	31,7	36,2		
284	21,4								26,8	32,1	37,5	42,8	53,5	
300	21,9								28,3	33,9	39,6	45,2	56,5	
355	21,9								33,5	40,1	46,8	53,5	66,9	83,6
375	21,9	34,1	42,4	49,5	56,5	70,7	88,4							
400	21,9	34,1	45,2	52,8	60,3	75,4	94,2							
500		34,1	49,2	66,0	75,4	94,2	117,8							
600			49,2	66,9	87,4	113,1	141,4							
700				66,9	87,4	131,9	164,9							
800					87,4	136,6	188,5							
900						136,6	212,1							
1000						136,6	213,4							
Length to develop steel yield, $L_{b,rqd}$ [mm]			290	362	435	580	725	725	906					

Values shaded in light blue are not allowed for overlapping joints

CONCRETE CLASS 40/50

Concrete compressive strength [$f_{ck,cube}$]: 50 N/mm²

Rebar ϕ	d_s	[mm]	$\phi 8$	$\phi 10$	$\phi 12$	$\phi 14$	$\phi 16$	$\phi 20$	$\phi 25$
Rebar Size	d_s	[mm]	8	10	12	14	16	20	25
Cross-sectional area	A_s	[mm ²]	50,3	78,5	113,1	201,1	314,2	314,2	490,9
Steel Yield	f_{yd}	[kN]	500	500	500	500	500	500	500
Partial safety factor	$\gamma_{M,s}$	[mm ²]	1,15	1,15	1,15	1,15	1,15	1,15	1,15
Design steel resistance	$N_{Rd,s}$	[kN]	21,9	34,1	49,2	87,4	136,6	136,6	213,4
Bond stress	f_{bd}	[N/mm ²]	3,70	3,70	3,70	3,70	3,70	3,70	3,00
Drilled hole diameter	d_h	[mm]	10 ~ 12	12 ~ 14	16	18	20	25	32
Bar spacing \geq	s	[mm]	50	50	60	80	100	100	125
Edge distance (compressed air drilling) \geq	c	[mm]	$50 + 0,06 L_b$						
Edge distance (hammer drilling) \geq	c	[mm]	$30 + 0,08 L_b \geq 2\phi$						
Anchorage length, L_b [mm]			Design tensile pull-out bond resistance, N_{Rd} [kN]						
114	10,6								
142	13,2	16,5							
171	15,9	19,9	23,9						
200	18,6	23,2	27,9	32,5					
210	19,5	24,4	29,3	34,2					
227	21,1	26,4	31,7	36,9	42,2				
240	21,9	27,9	33,5	39,1	44,6				
284	21,9	33,0	39,6	46,2	52,8	66,0			
300	21,9	34,1	41,8	48,8	55,8	69,7			
355	21,9	34,1	49,2	57,8	66,0	82,5	83,6		
375	21,9	34,1	49,2	61,0	69,7	87,2	88,4		
400	21,9	34,1	49,2	65,1	74,4	93,0	94,2		
500		34,1	49,2	66,9	87,4	116,2	117,8		
600			49,2	66,9	87,4	136,6	141,4		
700				66,9	87,4	136,6	164,9		
800					87,4	136,6	188,5		
900						136,6	212,1		
1000						136,6	213,4		
Length to develop steel yield, $L_{b,rqd}$ [mm]			235	294	352	470	587	587	906

Values shaded in light blue are not allowed for overlapping joints

CONCRETE CLASS 50/60

Concrete compressive strength [$f_{ck,cube}$]: 60 N/mm²

Rebar \emptyset	d_s	[mm]	$\emptyset 8$	$\emptyset 10$	$\emptyset 12$	$\emptyset 14$	$\emptyset 16$	$\emptyset 20$	$\emptyset 25$
Rebar Size	d_s	[mm]	8	10	12	16	20	20	25
Cross-sectional area	A_s	[mm ²]	50,3	78,5	113,1	201,1	314,2	314,2	490,9
Steel Yield	f_{yd}	[kN]	500	500	500	500	500	500	500
Partial safety factor	$\gamma_{M,s}$	[mm ²]	1,15	1,15	1,15	1,15	1,15	1,15	1,15
Design steel resistance	$N_{Rd,s}$	[kN]	21,9	34,1	49,2	87,4	136,6	136,6	213,4
Bond stress	f_{bd}	[N/mm ²]	4,30	4,30	4,30	4,30	4,30	3,70	3,00
Drilled hole diameter	d_h	[mm]	10 ~ 12	12 ~ 14	16	18	20	25	32
Bar spacing \geq	s	[mm]	50	50	60	80	100	100	125
Edge distance (compressed air drilling) \geq	c	[mm]	$50 + 0,06 L_b$						
Edge distance (hammer drilling) \geq	c	[mm]	$30 + 0,08 L_b \geq 2\phi$						

Anchorage length, L_b [mm]

Design tensile pull-out bond resistance, N_{Rd} [kN]

114	12,3								
142	15,3	19,2							
171	18,5	23,1	27,7						
200	21,6	27,0	32,4	37,8					
210	21,9	28,4	34,0	39,7					
227	21,9	30,7	36,8	42,9	49,1				
240	21,9	32,4	38,9	45,4	51,9				
284	21,9	34,1	46,0	53,7	61,4	66,0			
300	21,9	34,1	48,6	56,7	64,8	69,7			
355	21,9	34,1	49,2	66,9	76,7	82,5	83,6		
375	21,9	34,1	49,2	66,9	81,1	87,2	88,4		
400	21,9	34,1	49,2	66,9	86,5	93,0	94,2		
500		34,1	49,2	66,9	87,4	116,2	117,8		
600			49,2	66,9	87,4	136,6	141,4		
700				66,9	87,4	136,6	164,9		
800					87,4	136,6	188,5		
900						136,6	212,1		
1000							136,6	213,4	
Length to develop steel yield, $L_{b,rqd}$ [mm]		202	253	303	404	505	587	906	

Values shaded in light blue are not allowed for overlapping joints

VALUES FOR PRE-CALCULATION OF ANCHORING WITH MOEPSE INJECTION SYSTEM

REBAR \varnothing	$\alpha_2 = \alpha_5 = 1,0$			$\alpha_2 \text{ or } \alpha_5 = 0,7$		
	Anchorage length ℓ_{bd}	TENSION LOAD	MORTAR VOLUME V	Anchorage length ℓ_{bd}	TENSION LOAD	MORTAR VOLUME
[mm]	[mm]	[kN]	[ml]	[mm]	[kN]	[ml]
8	114	6,6	9	114	9,4	9
	170	9,8	13	170	14,0	13
	270	15,6	21	210	17,3	16
	320	18,5	25	240	19,8	19
	378	21,9	29	265	21,9	20
10	142	10,3	13	142	14,7	13
	270	19,5	25	240	24,8	22
	340	24,6	31	270	27,9	25
	400	28,9	37	300	31,0	28
	473	34,2	43	331	34,2	30
12	171	14,8	18	171	21,2	18
	330	28,6	35	290	35,9	31
	410	35,6	44	320	39,6	34
	480	41,6	51	360	44,6	38
	567	49,2	60	397	49,2	42
14	199	20,1	24	199	28,8	24
	298	30,1	36	298	43,1	36
	470	47,5	57	380	54,9	46
	570	57,7	69	420	60,7	51
	662	67,0	80	463	66,9	56
16	227	26,2	31	227	37,5	31
	340	39,3	47	340	56,2	47
	540	62,4	74	430	71,0	59
	650	75,1	89	480	79,3	66
	756	87,4	103	529	87,4	72
20	284	41,0	61	284	58,6	61
	425	61,4	91	425	87,7	91
	680	98,3	145	540	111,6	115
	810	117,1	172	600	123,9	128
	945	136,6	201	662	136,7	141
25	355	64,1	134	355	91,6	134
	532	96,1	201	532	137,3	201
	760	137,3	286	670	172,9	252
	880	159,0	331	750	193,5	283
	1000	180,6	377	827	213,4	311

* Examples for C20/25 ($f_{bd} = 2,3 \text{ N/mm}^2$), good bond conditions, rebars ($f_{yk} = 500 \text{ N/mm}^2$)

VALUES FOR PRE-CALCULATION OF OVERLAPPING WITH MOEPSE INJECTION SYSTEM

REBAR Ø	$\alpha_2 = \alpha_5 = \alpha_6 = 1,0$			$\alpha_2 \text{ or } \alpha_5 = 0,7; \alpha_6 = 1$		
	Lap splice length ℓ_{bd}	TENSION LOAD	MORTAR VOLUME V	Lap splice length ℓ_{bd}	TENSION LOAD	MORTAR VOLUME
[mm]	[mm]	[kN]	[ml]	[mm]	[kN]	[ml]
8	200	11,6	16	200	16,5	16
	250	14,5	19	250	20,6	19
	330	19,1	25	300	24,8	23
	350	20,2	27	--	--	--
	378	21,9	29	--	--	--
10	200	14,5	19	200	20,6	19
	300	21,7	28	250	25,8	23
	380	27,5	35	300	31,0	28
	420	30,3	38	331	34,2	30
	4713	34,2	43	--	--	--
12	200	17,3	22	200	24,8	22
	300	26,0	32	300	37,2	32
	430	37,3	46	340	42,1	36
	500	43,4	53	370	45,8	40
	567	49,2	60	397	49,2	42
14	210	21,2	26	210	30,3	26
	315	31,9	38	315	45,5	38
	480	48,6	58	380	54,9	46
	570	57,7	69	420	60,7	51
	662	67,0	80	463	66,9	56
16	240	27,7	33	240	39,6	33
	360	41,6	49	360	59,5	49
	550	63,6	75	440	72,7	60
	650	75,1	83	480	79,3	66
	756	87,4	103	529	87,4	72
20	300	43,4	64	300	61,9	64
	450	65,0	96	450	92,9	96
	69	99,7	147	550	113,5	117
	820	118,5	174	600	123,9	128
	945	136,6	201	662	136,7	141
25	375	67,7	142	375	96,8	142
	563	101,7	212	563	145,3	212
	780	140,9	294	690	178,1	260
	890	160,8	335	760	196,1	286
	1000	180,6	377	827	213,4	311

* Examples for C20/25 ($f_{bd} = 2,3 \text{ N/mm}^2$), good bond conditions, rebars ($f_{yk} = 500 \text{ N/mm}^2$)

9. CHEMICAL RESISTANCE

Chemical resistance of the product for different kind of chemical environments and for a specific concentration.

Chemical Environment	Concentration	Result	Chemical Environment	Concentration	Result
Aqueous Solution Acetic Acid	10%	✓	Hexane	100%	C
Acetone	100%	X	Hydrochloric Acid	10%	✓
Aqueous Solution Aluminium Chloride	Saturated	✓		15%	✓
Aqueous Solution Aluminium Nitrate	10%	✓		25%	C
Ammonia Solution	5%	✓	Hydrogen Sulphide Gas	100%	✓
Jet Fuel	100%	✓	Isoproyl Alcohol	100%	C
Benzene	100%	X	Linseed Oil	100%	✓
Benzoic Acid	Saturated	✓	Lubricating Oil	100%	✓
Benzyl Alcohol	100%	X	Mineral Oil	100%	✓
Sodium Hypochlorite Solution	5 - 15%	C	Paraffin / Kerosene (Domestic)	100%	✓
Butyl Alcohol	100%	C	Phenol Aqueous Solution	1%	X
Calcium Sulphate Aqueous Solution	Saturated	✓	Phosphoric Acid	50%	✓
Carbon Monoxide	Gas	✓	Potassium Hydroxide	10% / pH13	C
Carbon Tetrachloride	100%	✓	Sea Water	100%	✓
Chlorine Water	Saturated	✓	Styrene	100%	X
Chloro Benzene	100%	X	Sulphur Dioxide Solution	10%	✓
Citric Acid Aqueous Solution	Saturated	✓	Sulphur Dioxide (40°C)	5%	✓
Cyclohexanol	100%	✓	Sulphuric Acid	10%	✓
Diesel Fuel	100%	✓		50%	✓
Diethylene Glycol	100%	✓	Turpentine	100%	C
Ethanol	95%	✓	White Spirit	100%	✓
Ethanol Aqueous Solution	20%	C	Xylene	100%	X
Heptane	100%	✓	Contact only to a maximum of 25°C.		C
Resistant to 75°C with at least 80% of physical properties retained.		✓	Not Resistant		X

10. OFFICIAL DOCUMENTATION

The following documents are available through our Sales Department or on our official website: www.indexfix.com:

- MOH Safety Data Sheet.
- European Technical Assessment ETA 14/0138 for use on cracked and non-cracked concrete according to EAD 330449-00-0601 Guide, option 1, for M8 to M30. Assessment for seismic loads C1.
- European Technical Approval ETA 13/0785 for the installation of post-installed rebar with diameters from 8 to 25 mm according to EAD 330087-00-0601 Guide.
- European Technical Assessment ETA 16/0841 for the use in masonry according to EAD 330076-00-0604 Guide.
- Classified A+ according to French Regulation DEVL11044875A relative to the emission of volatile pollutants for indoor use.
- LEED MOH Certification of sustainability.
- Certification AVCP 1020-CPR-090-032411 for use in concrete.
- Certification AVCP 1020-CPR-090-043513 for post-installed rebar.
- Certification AVCP 1020-CPR-090-036865 for use in masonry.
- WRAS certificate - 160454 of material admitted for use in contact with drinking water.
- IBMB certificate – (2101/941/16) – CM of 24/01/2017 of behavior of material in contact with fire.
- Declaration of Performance DoP MOH.
- INDEXcal anchor calculation software.
- INDEXmor cartridge calculation needs software.